

Ultima™ Diaphragm Flush Valves

STOP VALVE RUN-ON BEFORE IT STARTS

Our exclusive DynaClean™ self-cleaning technology is engineered to stop valve run-on due to clogging. Equipped with a self-cleaning wiper spring, every flush clears debris and build-up, averting valve run-on and excess water usage.



*American
Standard*

Manual and Sensor-Operated Diaphragm Flush Valves

Self-Cleaning Technology Prevents Valve Run-On Due to Clogging

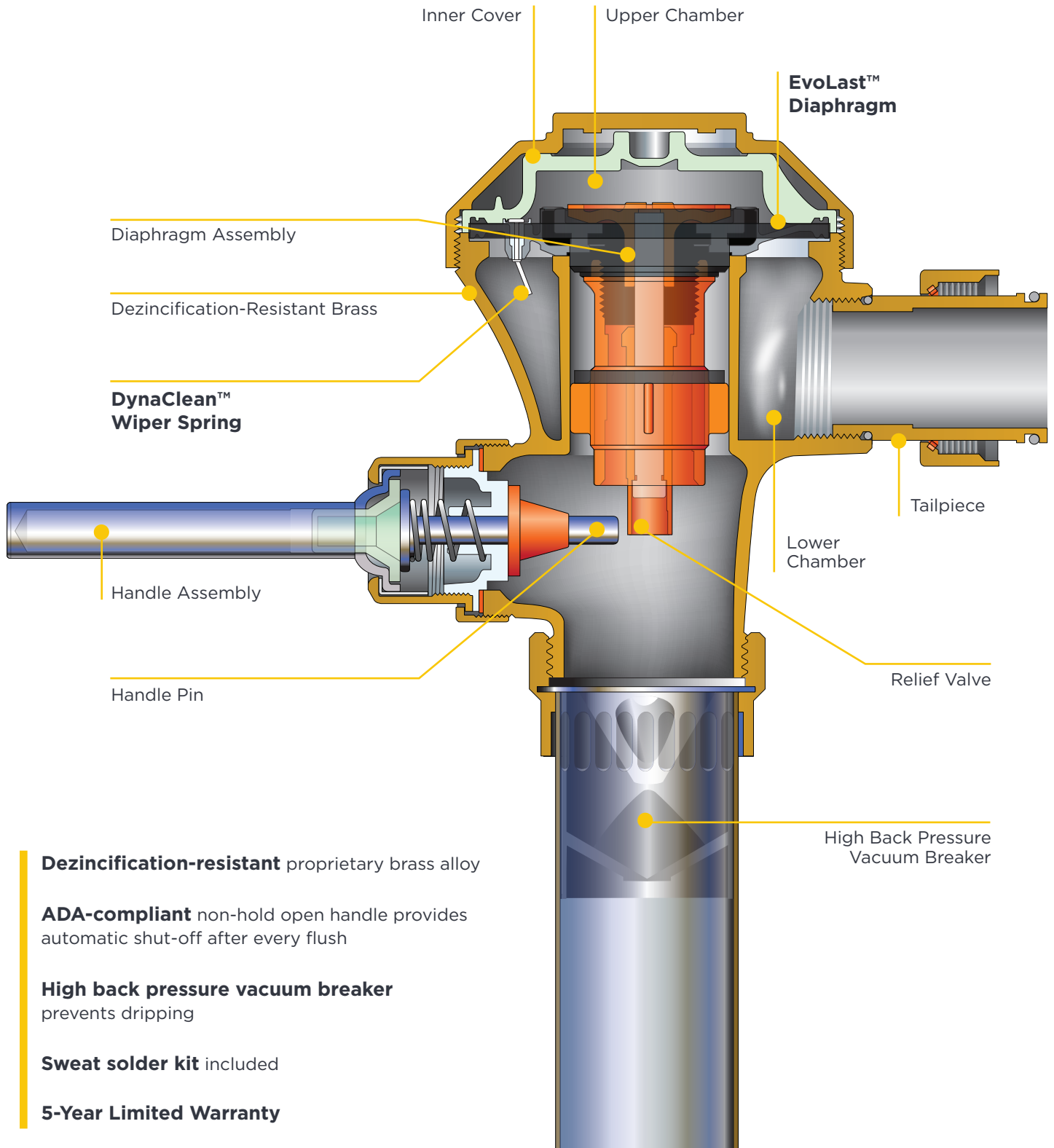

Ultima™ Diaphragm Flush Valves

Reduce Maintenance and Downtime, Save Water

CLOG-REDUCING TECHNOLOGY AND MORE

These diaphragm flush valves offer a common-sense solution to the all-to-common problem of valve run-on caused by clogging.

SUPERIOR PERFORMANCE AND DURABILITY

These flush valves include our exclusive self-cleaning technology and superior materials to out-perform and out-last traditional diaphragm flush valves.



DynaClean Wiper Spring

DynaClean, our exclusive, self-cleaning technology, cleans the refill orifice with every flush, preventing valve run-on. The integral wiper spring keeps the orifice clear of debris and mineral build-up for improved performance and less maintenance.

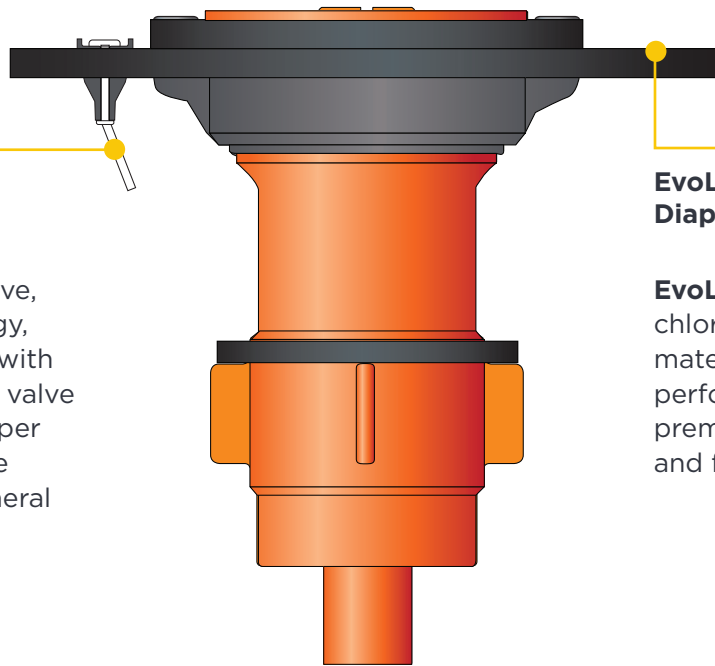

EvoLast Diaphragm

EvoLast, a premium, chlorine-resistant diaphragm material delivers consistent performance and resists premature deterioration and failure.

EASY RETROFIT, ENHANCED PERFORMANCE

Ultima Flush Valves are easy to retrofit in place of most popular piston and diaphragm flush valves. The industry standard rough-in dimensions allow for an easy switch.

Ultima Diaphragm Assemblies can be installed in diaphragm flush valves from other major manufacturers, making it easy to improve performance and ensure reliability in existing applications.



Durable, dezincification-resistant brass construction outside and clog-resistant technology inside ensure on-site dependability and a significant reduction in maintenance, even in the most demanding locations.

Urinal Flush Valves



Washbrook® Urinal shown with Ultima™ Manual Diaphragm Flush Valve



6145 Series
Manual Urinal Flush Valves
(0.125, 0.5 and 1.0 gpf)*



6145SM Series
Sensor-Operated Urinal Flush Valves
(0.125, 0.5 and 1.0 gpf)*

Toilet Flush Valves



Madera™ Toilet shown with Ultima Sensor-Operated Diaphragm Flush Valve



6147 Series
Manual Toilet Flush Valves
(1.1, 1.28 and 1.6 gpf)*



6147SM Series
Sensor-Operated Toilet Flush Valves
(1.1, 1.28 and 1.6 gpf)*

Clinic Sink Flush Valves are also available.

*WaterSense for 0.125 gpf and 0.5 gpf urinals and 1.1 gpf and 1.28 gpf toilets only.

